

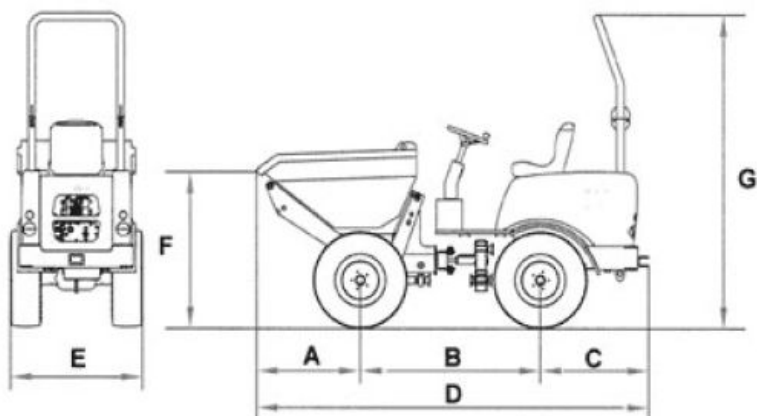

DUMPERS

ROTATING UNLOADING



A	860 mm.
B	1500 mm.
C	900 mm.
D	3260 mm.
E	1100 mm
F	1260 mm.
G	2520 mm.
H	
I	
J	
K	
L	
M	
N	

MZ-1202-HDG-H HIDROSTATIC

Working load	1.200 kg.
Wheels	
Driving	
Steering	
Hopper capacity	
Water level	355 l.
Heaped up	505 l.
Diesel engine	
Power	20,0 H.P.
N° Cylinders	3
Cooling	Water
Transmission	Hydrostatic-4 engines wheels
Gearbox	Pump with variable flow Automatic regulation Electrical reverse in joystick Wheels with
Maximum speeds with load	18 km/h.
Clutch	-
Stering	Hydraulic with doble effect cylinder in central joint With priority valve LOAD SENSING
Brakes	Hydrostatic
Tipping system	Rotating hydraulic 1,05 m
Electrical star	yes
Weight with no load	1.100 kg.
Turning radius	
Outer	3 m (Wheels 10.0/75-15.3) - 2,95 m (Wheels 7.5L-15)
Inner	
Driving post	
Factory equipped	Ergonomic driving post. Protection folding arch ROPS Rotating light. Rear view mirror. Backwardas warning acoustic installation
Optional	Lighting equipment installation